



ZM TECHNOLOGIES

2250 STEWART St. UNIT #6
STOCKTON CA. 95205
PHONE (209) 547-1965
FAX (209) 464-8140

www.zmtech.com

INSTALLATION INSTRUCTIONS

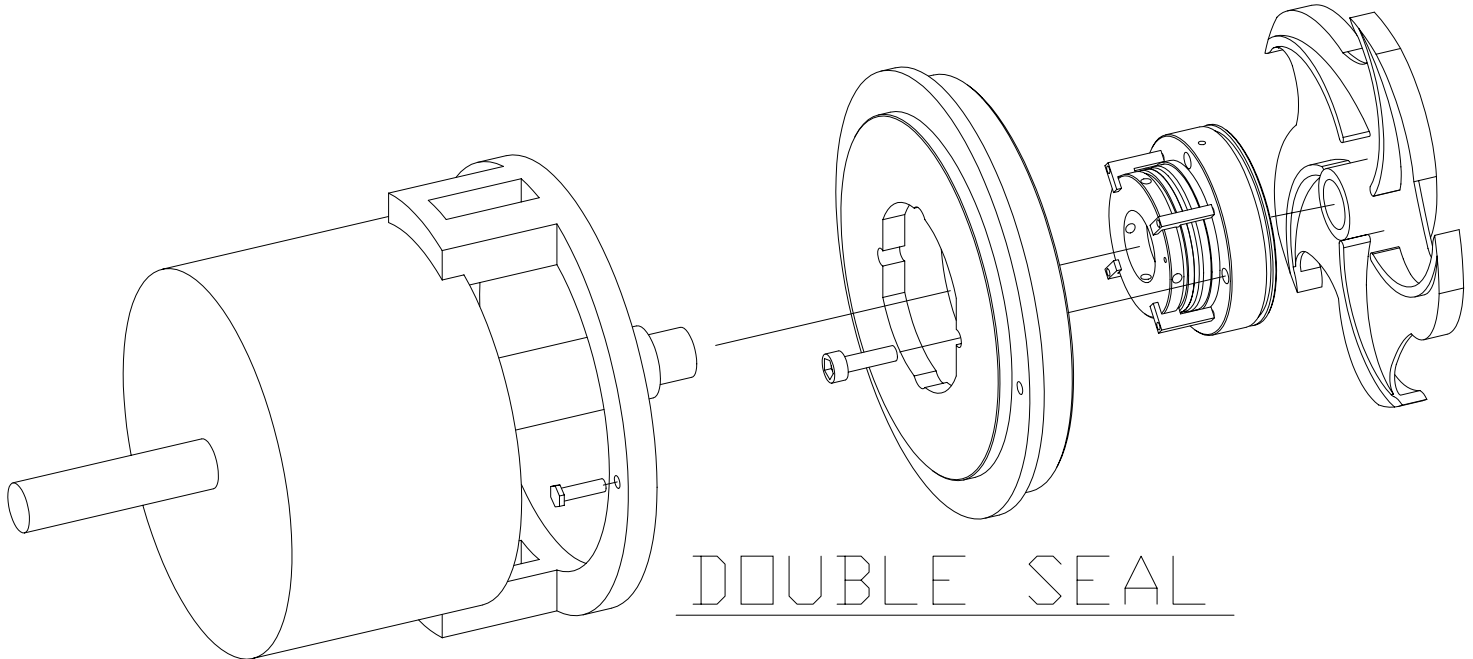

- 1) BOLT THE ZMT BACK PLATE, USING TWO BOLTS, TO THE POWER FRAME ADAPTER. BOLT THE BACK PLATE IN THE SAME PLACE WHERE THE STUFFING BOX WOULD BE NORMALLY.
- 2) LUBRICATE O-RINGS ON GLAND & ROTARY COMPONENTS.
- 3) SLIDE SEAL INTO THE BACK PLATE WITH THE RED CLIPS TOWARD THE BEARING FRAME. USING THE TWO SOCKET CAP SCREWS PROVIDED, BOLT SEAL IN PLACE.
- 4) TIGHTEN IMPELLER AGAINST SLEEVE.
- 5) ADJUST FOR IMPELLER CLEARANCE.
- 6) TIGHTEN THE FOUR SET SCREWS.
- 7) REMOVE THE RED CLIPS.
- 8) INSTALL TWO 1/8" X 3" NIPPLES FOR FLUSH CONNECTIONS.
- 9) HOOK UP FLUSH CONNECTOR WITH FLUSH MEDIA IN THE BOTTOM CONNECTION & OUT THE TOP.
- 10) ROTATE SHAFT TO CHECK TIGHTNESS.